



The Road to the Consumer

For small growers and food manufacturers

ACKNOWLEDGEMENTS

This document was originally created by Angelyn DeYoung, Marketing Officer for the Montana Department of Agriculture's Agricultural Marketing & Business Development Division. The content was taken from:

- published resources
- interviews with food manufacturers, distributors, warehouses, and independent retailers
- guidance from other states and Canadian provinces

This document was adapted for use in Manitoba by Manitoba Agriculture.

DISCLAIMER

While every effort has been made to ensure accuracy, none of the sponsoring agencies or authors accepts responsibility for errors or omissions. The publisher, editors and all contributors to this publication cannot be held responsible for publication errors or any consequences resulting from the use of this publication.

CONTENTS

1	Introduction	1
	Grocery Stores.....	1
	A Road Map	2
2	First Considerations	3
3	Grocery Store Readiness.....	5
	Product	5
	Packaging	6
	The Road to the Consumer – Options.....	11
	Distribution	11
	Pricing	15
	Business Practices.....	18
	Marketing	20
4	Making the Presentation	25
5	Glossary	28
6	Attachments.....	33
7	References.....	34



1 INTRODUCTION

For small growers and food manufacturers, the road to the consumer is varied. Many start selling direct to the consumer through farmers markets and Internet stores, then move on to specialty food and gift stores. Once their product is established, the small food manufacturer begins to seek opportunities for larger volume sales through grocery stores.

GROCERY STORES

How grocery stores work. Grocery stores, like brokers, distributors and manufacturers, are running a business. They want to purchase successful products that will sell well. They want to stock products that their customers demand. They also want a good deal and to make a decent, if not sizeable, margin.

Most grocery stores are looking for unique products. A big draw is convenience items, but organic and natural items, as well as gluten-free products, also have wide appeal.

Purchasing is done by buyers or category managers, depending on the size of the store. Larger grocery stores have category managers who purchase and maintain products in particular categories for many stores. Buyers and category managers deal with many people and have a good understanding of what their customers want. They decide which products will be placed on store shelves, purchase products from distributors and manufacturers and work with brokers.⁵

A good start. Retailers, large and small, agree that it usually is best to start small, with independently-owned grocers, and work your way up to the big players. This progression allows you to gain experience, learn how to play the game and build production and delivery capacities.⁵ Note, however, that more than 2,000 new food products are introduced into the Canadian market each year (over 20,000 are introduced into the United States market each year), and 90 per cent of these products will fail on the shelf. While the average food retailer may have to replace several hundred or several thousand new products each year, new and innovative products are becoming increasingly difficult to find.

Independents defined. Independent grocery stores, for the purposes of this manual, are defined as stores that are normally independently owned (often locally owned) and typically smaller in size than larger chain stores. They offer a complete lineup of all standard grocery items and brands and are usually part of a buying group (such as TGP – The Grocery People, or Macdonald’s Consolidated). Unlike regional and national owned chains, local independents:

- make decisions at the store or local distribution warehouse level
- usually have fewer product requirements, making it easier to enter the market
- allow in-person sales visits at the store
- are involved in the local community

Independent grocery stores are finding they can differentiate from larger chain grocery stores by offering locally-made products. This demand opens an opportunity for local products that hasn’t been seen since the beginning of grocery consolidation.¹¹

Common concerns. Retailers working with new manufacturers voice several concerns about the manufacturers. The most common are:⁵

- their inability to supply all stores (if a chain)
- not sticking to the agreed-upon promotional plan
- inability to supply the volume required by stores
- not following up with the retailer after the initial sale
- inability to acquire and use technology
- inability to resupply stores quickly when needed
- not conducting in-store demonstrations
- not understanding how pricing works
- pricing products well above the competition



A ROAD MAP

This manual provides small growers and food manufacturers with the most comprehensive guide to date – a detailed road map for successfully selling to consumers through independent grocery stores. It has been compiled from industry experts, research reports and how-to-guides. To use the manual effectively:

- Start at the beginning, as though this were your checklist for success.
- Cross off the items you've already done.
- Circle the items you need to do.
- View all of the website and attachment resources provided.
- Take notes throughout the manual as to how your product or businesses addresses retailer needs.
- Ask for guidance from your local store managers.
- Seek advice from other small growers and food manufacturers who are successfully selling to grocery stores.
- Use all of this information to develop your presentation.

Done properly, selling your product to consumers should make money for your company and all of the intermediaries, such as brokers, distributors, warehouses and grocery stores.

2 FIRST CONSIDERATIONS

A small food manufacturer must consider a few items before starting down the road to grocery sales.

Where do you shop? Do you regularly shop at the store that you're asking to carry your products? When you're in the store, do you seek out local products? If you're not shopping at the stores that carry local products and buying them, why would the store buy from you?

Business or hobby? You must consider your needs and the needs of your business. Is this your full-time business, or are you making a product on the side while keeping a day job? For the sake of the reputation of local products among store owners, we suggest you should only pursue selling your product to more than a handful of grocery stores if this is your primary source of income. If you are part-time (i.e., NOT at least 8-5, Monday to Friday), then selling to a handful of grocery stores is possible, but you will not likely be successful pursuing warehouse, distribution, and non-local stores.

Legal considerations. To legally sell your food product to any grocery store, your product must be produced in a licensed commercial kitchen or in a facility such as Manitoba's Food Development Centre. Your product must also be labelled according to the regulations as outlined by the Canadian Food Inspection Agency and include a valid nutrition facts table to inform consumers about the nutritional content of your food product.

- A list of licensed commercial **community kitchens** in Manitoba is available online.
- You can learn more about and contact Manitoba's **Food Development Centre** regarding labelling regulations and nutrition facts.

Business licences. To operate a food business in Manitoba, you are required to register and license that business. For more information, please visit the Entrepreneurship Manitoba website at www.entrepreneurshipmanitoba.ca



Targeted consumer. When preparing your product sales strategy, you may need a more detailed description of your target consumer. Ask yourself these questions:²

1. Who is your product's target consumer? Consider age, gender, income level, household spending and lifestyle.
2. Why are they going to purchase your product? List the product's points of differentiation, such as taste, ingredients, portion size, uniqueness, ease of use, health benefits, local, etc.
3. What benefits are they looking for in a product that is similar or substitutable? Look on the packaging of your competitors in the store – what messages are they conveying to customers?

Finding the right retailer. To find the right retailer for your product, ask yourself these questions²:

1. Is the retailer's trade profile compatible with your product? If the average retail in a specific store for your type of product is \$4.99, and your target retail is \$6.99, then your product might not fit into the assortment.
2. Does the store carry your product category? Most retailers will not introduce a new product into their store unless they already have other products in that category.
3. Is there a gap or can a gap be created in the product assortment? The gap could be a missing flavor, price point, type of product, etc.
4. What product could your product replace in the assortment? Often the shelf is crowded, and in order to create a space for your product, an existing product must be removed.
5. Does your product complement the assortment? For example, if you're selling rhubarb jam, and the retailer has other jams but no rhubarb flavor, then your product complements the assortment by offering consumers a new choice in product.



Viewing the shelf on which your product would be is great research for what your product needs to compete.

6. Do the product benefits meet a consumer food trend? Do an internet search for the top 10 food trends. Does your product meet any of those consumer needs?
7. Can the product increase profitability to the category? Retailers don't like to replace a product that is selling well with a new and unproven product. You must prove that your product will help to grow the category.

Store visit. Next, visit the aisle in which you think your product belongs and look at the breadth of similar products on the shelves.

1. **Product comparison.** If there are no similar products, then congratulations, you already have a leg up! Now ask yourself, why aren't there any other products like mine on the shelves? Is it because your product is a new idea, or is it because there is no demand for your product in that market?
2. **Product replacement.** Consider what products your product will replace on the shelves. These products probably have established sales records and customers. What benefit will the stores receive from displacing those proven products with yours? It could be increased sales, freshness, less waste, higher profit margin, etc. If you do not have any reason for your product to replace proven product on the shelves, how are you going to convince the store owner?

3. **Price.** How does the suggested retail price of your product compare with that of similar products on the shelves? If your item retails for significantly more than the other products on the shelves, that might be a red flag that your product is either priced too high or not meant for grocery sales. Keep in mind that while some consumers do look at price per serving, which may make your product more affordable, many do not spend the time to find or determine those factors.
4. **Packaging.** How does the packaging of your product compare to that of similar products on the shelves? Is your package appropriately sized (ex: does it fit into the average shelf space, including the width, depth, and height of similar products on the shelf)? Does your packaging look professional compared to that of products already on the shelves? If your answer to these questions is no, ask yourself if your product is ready for grocery store shelves.

If your product withstands this visit, then you're ready to continue with next steps.

If not, then you need assistance with getting your business and product ready for wholesale sales. There are two groups that can provide assistance free of charge:

- [Manitoba Agriculture](#)
- [Entrepreneurship Manitoba](#)



3 GROCERY STORE READINESS

The next step is to provide you with the information necessary to get your product ready for grocery store sales.

PRODUCT

First, you must evaluate your product for grocery store readiness.

Family of products. Most food companies introduce a “family” of products into the market. Retailers prefer to review a family of products rather than a single item. Experience has taught them that a single item can get lost in the assortment unless the retailer stocks many facings of the product.² This doesn’t mean you’ll fail if you only have a single item to introduce. This is provided to help you to understand how grocers operate.

Shelf life. Is your shelf life long enough that the grocery store will get it sold before it expires? Does your shelf life allow enough time for your product to be warehoused and distributed throughout the province or to neighbouring provinces? Note that products requiring refrigerated or frozen shelf space will have a much harder time getting placed because

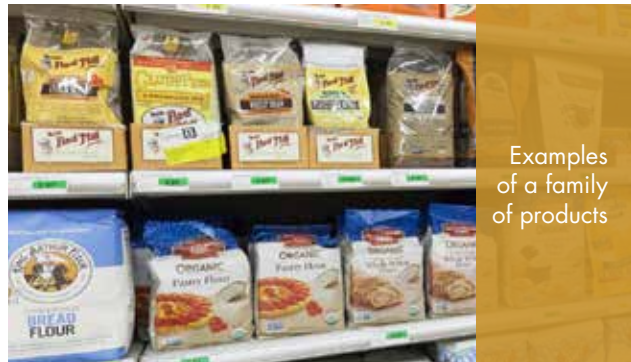

Examples of a family of products

refrigerated and frozen space is typically limited in a store.

Manufacturing volume. Can you sustain the manufacturing volume necessary to consistently supply a store or several stores? As a worst case scenario, can you manufacture enough products or do you have enough inventory to supply at least one

case of product to all of the stores in the warehouse's distribution route? Can you maintain manufacturing and inventory levels to provide uninterrupted volume to the stores? Do you have a plan for out of stock or back ordered product? Many retailers have adopted the practice of levying financial penalties to product suppliers that don't fulfill their orders. If your product is seasonal, then considerations can be made at the store level, but you must be able to provide this information upfront.

Order fulfillment time. This is a key business factor. If you want to sell your product through a warehouse and distribution system, the product must be in warehouse two weeks or less from the purchase order date. This means that you must have an inventory of your product ready for large quantities of sales, or you must be able to produce your product quickly to supply pallet-sized orders on time. You must factor in transit time from you to the warehouse, as well.⁷

Expected sales volume. What is your expected sales volume? Do you have any current sales data that you could provide to prove that your product is in demand and moving off shelves? If you're a new company, then you likely don't have this data, so estimates based on industry data could be acceptable. You might even consider working with your hometown grocery stores for a while to generate sales data useful for introduction into larger markets.

If you have been successfully selling your product at the local farmers' market, by all means track and use that data to present your product. Granted, each sale is a direct sale and you may have pitched every customer to buy your product, but there will also be a certain level of repeat sales as you become familiar with your regular customers over time. This is valuable data that can do an excellent job of speaking to the success your product already has experienced.

New-to-market products. If you are producing a new product that isn't yet available in stores (i.e., no direct competition), this can be an opportunity or a challenge.



- **Opportunity.** It is an opportunity if the store owner has no other products to replace with yours. If your product is in demand and short supply, then your product should sail through the approval process.
- **Challenge.** If your product is so new that people don't know they need it yet, then you may experience a challenge getting it through the process. Educating consumers about new products and their uses is a difficult and expensive challenge that many stores will not take on. It is ultimately your responsibility to sell your product in a retailers' store, not the retailer's.

PACKAGING

There isn't any easily summarized information on packaging standards, so a great first step is direct research. Stand in the aisle, observe products in your category and see how yours compares. The way your product is packaged could be a benefit or a detriment to your readiness for grocery stores.

There are two considerations when it comes to packaging: unit packaging and case packaging.





Examples of different packaging for similar products

Unit packaging considerations. Unit packaging refers to the individual packages in which your product is sold, such as a jar of jam.

- **Packaging material.** This is an important factor in a store owner and consumer's choice. Ask yourself these questions:
 - What material is used for packaging similar products? Is it in a box, a clear bag or a jar? If the packaging materials differ, how does that correlate with the price?
 - If your products are packaged differently, will store owners or consumers see that as a benefit or a detriment? For example, if your organic yogurt is packaged in a non-recyclable container, will your customers see that as a deterrent to buying your product? Or, if your product is more expensive but your package provides twice as much product as the on-shelf competition, will your customers take the time to compare the price per serving, rather than the overall price listed on the shelf?
 - Does the packaging appear to be made by a professional? As long as it appears professional, it doesn't matter whether you made the packaging yourself or designed and printed your own labels. This is a tricky area, though, so be honest with yourself. If you started out selling in gift stores, often the packaging and labels that are acceptable in gift stores don't translate to grocery stores. If it doesn't look professional, you will need to look at your profit margin and see if there is room for additional printing costs.

You might be surprised. When you factor in your time, ink cartridges, paper and your mistakes, you might find professional printing is cheaper.

- **Marketing messages.** What messages stand out on the package? Does the packaging claim to be eco-friendly? Is the product marketed as heart healthy or part of a balanced diet? Consider these messages for your product.
 - Note: for health claims on a product, you must be very careful to follow the regulations. See:
 - [Food Labelling for Industry](#)
 - [Health Claims](#)
- **Certifications.** If your product is certified organic, Kosher or gluten free, be sure to include the appropriate label claims for each. See:
 - [organic certification](#)
 - [sustainable development](#)
 - [Orthodox Union for Kosher certification](#)
 - [gluten free certification](#)



- **Standing out.** Would your product stand out on the shelves? Your label and packaging could draw attention to your product.
 - One possible addition to your label that may make it stand out is to add the "Product of Canada" or "Made in Canada" designation and the stylized maple leaf design to the front of your label. Visit the [CFIA website](#) for more information.

- Consider packaging that is different than the competition but still applicable. For example, to call attention to their product in a sea of similar products, BeeMaid Honey launched one of their products in a plastic container shaped like a bear, since bears are known to love honey.



- Does your product merchandise well? Your product must sit on the shelf so that its “face” will be easily visible to the consumer. If your product is a small box, is it supposed to stack?
- If your product is packaged in bags, how will those bags sit upright?
- Are there creative ways to merchandise your product that will draw attention to it or make life easier for the store owner?

Case packaging. Case packaging refers to how your product is bundled into multi-unit shippers (ex: shipping a case of 24 products).

- **Standards.** The case packaging (or master pack) does not have to be fancy with slick graphics. However, it must convey important information:⁷
 - supplier name and contact information
 - product description
 - number of units per case, weight per unit
 - case bar code
 - product shelf life and/or lot number information for traceability
 - any special handling requirements (ex: fragile, cut lines, refrigeration or freezing required)
- **Pre-printed vs. applied label.** When it comes to the information conveyed on your master packaging, you have two choices: use pre-printed boxes or applied labels.
 - Pre-printed master pack boxes are widely used in the food industry but are not necessary for success in distribution warehouses.
 - You can buy one size of non-printed box and use it for all of your flavours or types and label the boxes for each different product. This is perfectly acceptable.

- If you are planning to recycle the boxes from your inner packages (such as a 12-pack of empty jars), be sure to remove any markings from the boxes previous use. If there are graphics on the outside of the box, you may want to consider breaking the box apart and reforming it with the graphics on the inside. This will avoid any confusion as to the boxes new contents.

Unit and case UPCs. This is a key success factor. To be successful selling through the warehouse and distribution system or individually to most grocery stores, your products must have both unit and case UPCs.⁷

- **Unit UPCs.** UPC stands for Universal Product Code and UPCs are often referred to as barcodes.



This helps warehouses, distributors and stores track their inventory more efficiently, saving both them and consumers time at the cash register. For retail units, a 12-digit UPC is required.⁷

- To learn how to get a UPC for your product, see the attachment, *UPC Barcode Basics*, provided by Manitoba Agriculture.

- **Case UPCs.** Case UPCs are not as well known or as widely used by small growers and food manufacturers, but they are a key success factor when considering marketing through a warehouse and distribution system. Case UPCs are used to mark cartons, cases, or pallets that contain products in order to take inventory or tally shipments quickly and accurately. For cases, a 14-digit barcode is required. This code is referred to as SCC-14 (shipping Container Code) or UCC-14 (Universal Container Code). They are used interchangeably. The SCC-14 code is derived from the individual product UPC. For

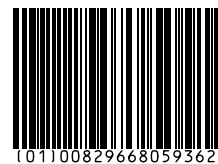

instructions on how to get a case barcode, refer to the attachment *Case Barcode Basics*, provided by Manitoba Agriculture. Remember, case barcodes do not have to be pre-printed on the box. You can print them on labels and attach them to the case packaging when preparing for shipping.

Uniform packaging. Uniformity is key success factor when considering warehousing and distribution.⁷

- **Uniform unit packaging.** Go to the grocery store with a tape measure in hand and take note of the average shelf space for the category including width, depth and height. Your packaging should be similar, as well as uniform and consistent and able to withstand normal wear from shipping and merchandising. It must also fit uniformly into case packaging, the next consideration.
- **Uniform case packaging.** For shipping cases directly to stores, uniformity is not as important, though the information conveyed on the case packaging must be consistent with standards. However, for warehousing and distribution, uniformity of case dimensions is required for your product to fit properly on the warehouse shelves and ship properly in the distributors' trucks.
 - Because the product may be traveling hundreds of kilometres in the distributor's trucks, it must be palletized uniformly.



- Forklifts unload the palletized products for staging in the warehouse. Non-palletized products mean more labor costs for warehouses.
- Palletized product is stored on shelves awaiting orders from retail stores.

Case pack considerations. Small growers and food manufacturers have options to consider, so they can be more competitive for store shelf space:

- **Master packs with inner-packs.** Master packs are full cases of your product (which often consists of 12 or 24 units). For small, independent grocers, buying a case of items with an expensive per unit cost (such as those that most small growers and food manufacturers offer) is an expensive *investment*. A case of 12 products that individually wholesale at \$5 would cost the grocer \$60. If you were to offer a master pack of 12 with two inner-packs of six units to the warehouse (they float the \$60 cost), the cost to the grocer would only be \$30, which is more palatable for small grocers. This also increases the odds that the entire case would get put out on the shelf and only need one shelf-facing, also an attractive attribute to a small grocer.⁷
 - Stores order product per case, not per individual retail package.
 - Product cases are pulled off the warehouse shelves and combined into palletized orders for the stores.

An option for packaging the inner-pack is to shrink-wrap the units to make the 6-pack. The simplest method of making an inner-pack is to buy shrink wrap bands and apply with a heat gun. More expensive automatic shrinkwrap band machinery is available, as your needs increase.

- **Mixed cases.** If you offer a product line of 12 flavors or sizes, it would be very difficult to get grocery stores to buy a case each of all 12. This would result in a large investment in your product and it would also require the displacement of 12 products on grocery shelves. For your introduction into stores, consider starting with offering only your top three selling flavors in mixed cases. If your case master pack is 12 boxes, then you could offer a case of four boxes each of your three best-selling flavors.⁷



Example of a shelf shipper-display

- **Shelf shipper-display.** These displays reduce material and inventory costs while making sure that your product gets the visibility it deserves. Shelf shipper-displays take the guesswork out of retail merchandising. Retailers simply remove the lid and place it on the shelf, reducing labour costs. You must ensure, however, that the shipper-display fits the store's shelf dimensions.

- **Point-of-purchase (POP) display shipper.** POP displays provide consumers with a preferred location to purchase, while also stimulating them to buy your product. Retailers love POP displays almost as much as manufacturers, because they are a proven way to help sell product and optimize sales space. These are also referred to as point-of-sale (POS) displays. They mean the same thing.



Example of a POP display shipper

- **Breaking cases.** Many retailers will ask you to break cases (ex: sell product in less than case lots). Breaking a case is costly, but it can be an important tool for building distribution with smaller retailers. Remember that every time a product is touched, either a case or a single unit, there is a cost – typically \$0.35 to \$0.50.²
- **Pallet configurations.** To sell in pallet volumes, you must also know your pallet configuration (ex: the way you stack your master packs on pallets for maximum storage efficiency and transport stability). The warehouse will ask for the tie and tier of your pallet. The tie is the number of cases per layer and the tier is the number of layers high the cases are stacked on the pallet.

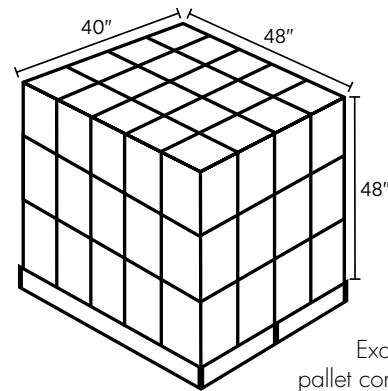

Example of a pallet configuration

THE ROAD TO THE CONSUMER – OPTIONS

DISTRIBUTION

There are several options for getting your product to consumers, as illustrated by the graphic below. This section will cover Options 2, 3, and 4.

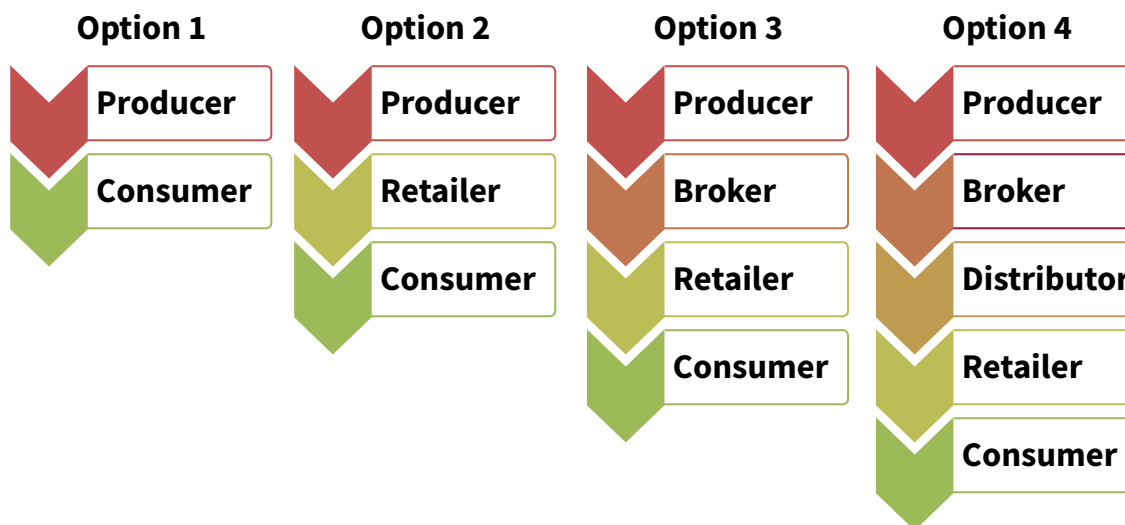

Direct-to-store delivery (DSD). Usually the first option that small growers and food manufacturers choose is DSD (Option 2), and it is usually done for case orders (not pallets). By delivering the items direct, you don't have to discount the wholesale price to allow for distributor margins, and you can also combine drop off with sales visits. Another DSD option is through a common carrier service, such as a local courier or trucking company that provides Less-Than-Truckload (LTL) service. However, unlike gift stores, grocery stores are not as likely to allow direct delivery. DSD means additional handling at their delivery dock and additional invoices to pay, and it requires additional points of contact for orders.

To determine if DSD is appropriate for your firm, consider your scale of operation—including labour requirements, transportation cost, and time requirements. If you are serious about selling to grocery stores on more than a local scale, you must consider distributors and warehouses.

Back-hauls and cross-docking. Back-hauls and cross-docking are moderate, non-committal options for delivery of your product to grocery stores.

- **Back-hauls.** A back-haul is moving freight from the destination point back to the point of origin. If a trucker takes a load from the warehouse to the store, the back-haul is a load going to stops along the route from the store back to the warehouse. This is a way for you to get your product from your facility to the distributor's warehouse for cross-docking, usually for a per-pallet fee:



1. Contact the distributor who visits the store(s) or other point(s) to which you need to deliver (possibly to connect with another distributor for delivery to stores on another route). The best-case scenario is that this distributor also has a delivery or pick up point near your facility.
 2. Determine if the distributor's truck can make an extra stop at your facility for pick up. For palletized product, distributors usually prefer that you have a loading dock. If the truck cannot stop at your facility, determine a meeting date, time, and location at a stop close by (perhaps a store with a loading dock).
 - It is important that you are never late or fail to show up for this stop, as this may harm your chances for a distributor relationship in the future.
 3. The truck delivers the product to the warehouse to be cross-docked for near-term distribution to the store.
- **Cross-docking.** This is a distribution system where items received at the warehouse are not received into stock, but are prepared for shipment to another location or for retail stores. Distributors usually charge a fee per pallet (regardless of the size of the load on the pallet), rather than a margin.
 - **Fees:** The fees are different for hauling shelf-stable, perishable, refrigerated and frozen product.
 - **Ownership:** For back-hauls and cross-docking, the ownership of the product does not transfer to the distributor. Instead, you retain ownership (and responsibility) for the product throughout its transit to the store.

Coordinating back-hauls and cross-docking requires a lot of work and coordination for both you and the distributor's office personnel. It is only recommended if you can't yet afford regular distribution.

Distributors. Distributors can add greatly to the volume of your business because they purchase your products in large quantities – usually by the pallet-load. Distributors can help small growers and food manufacturers in several ways:

1. by providing direct sales and delivery linkages with grocery stores (which may otherwise, be difficult to achieve on your own).

2. by taking responsibility for marketing, sales and (local) delivery to a wide variety of grocery customers (which is made possible by the variety and volume of products they handle and the sales force they employ).

- **Positive aspects of using distributors.**⁹ Just as distributors reduce costs for their customers, they also reduce some costs for you by simplifying your business.
 - Rather than dropping off product at multiple stores, distributors save gas and time for you by providing you with one drop off location, from which they will deliver to multiple accounts.
 - Because distributors handle goods in large quantities, they can help streamline your accounting and office procedures. For example, using distributors can reduce your order taking, customer service, billing, credit checking and bad debt losses because you will be dealing directly with far fewer accounts. For the same reason, your accounts receivable processing should become more efficient. Tracking your orders and sales communication should become much easier because there will be less paperwork and fewer individuals involved.
 - Distributors will develop an ordering cycle for products. Even when products are on promotion, many distributors operate under tight controls and cannot have more than six to eight weeks of inventory available. This means you'll know, often well in advance, when your product will be ordered so you can begin scheduling your production cycle.



3. by purchasing and paying for your products (usually at a lower price than you may secure elsewhere) on a regular basis knowing that your products are saleable to their customers.

Even though distributors provide small growers and food manufacturers a service, their target customer is the retailer or in this case the grocery store. For the grocer, distributors offer the convenience of one-stop shopping, processing orders quickly, delivering frequently, and offering a one invoice – one check system that saves the grocer time and expense.

- **Negative aspects of using distributors.**⁹ As with any business decision, the positives must be weighed with the negatives.
 - First, the cost involved. It either comes out of your profits or gets added to the retail price of your product. Distributors typically charge retailers 33 per cent to 50 per cent more than they pay for a product. Another way to express this is to say that distributors work on a 25 per cent to 35 per cent (gross profit) margin. See *Pricing* for more information on margins.
 - Next, with distributors, you lose control over various aspects of marketing your product. As example, if you use distributors, you may not know the specific retail price in the stores that carry your product. And you also lose control of important, individual store data. Your own invoices will no longer reveal the exact products you sell to each store. You will not know which sizes or flavors are in stock. You no longer will be able to analyze sales by geographic area, by store or by chain. You will not be able to tell if a specific store or chain discontinues your line or a specific item. With a distributor, retail promotion of your product becomes less controllable and less direct.
 - If you are just starting out, distributors may not be an option for you, because they may not be willing to even list your product. Further, for your product to get into the hands of retailers, someone must promote it to them and it would not make sense for a store sales representative to invest any time in talking about your unproven, unknown and untested product to retailers. A sales representative has limited time

with a retailer and will undoubtedly use that time to talk about upcoming activity with high volume items, for which the sales representative can make larger commissions.

Further investigation as to the pros and cons of a distributor is available in the attachment, *The Role of Distributors and Brokers*.

- **Independent vs. associated distributors.** What kind of distributor you pick will also determine the stores you can sell to. Independent distributors, also called voluntary wholesalers, are independent of retailers, so they can deliver to nearly any store in their coverage area. Associated distributors (called co-op grocery wholesalers), such as The Grocery People) are tied to specific retailers in their association. Asking them to deliver to stores outside of their association isn't possible.⁷
- **Specialty vs. broadline distributors.** Another consideration is how specific your distributor needs to be:
 - Specialty distributors focus upon a specific product category (ex: meat, dairy, produce, beverages, and ethnic foods) or segment (ex: grocery, food service). Like broadline distributors, they provide delivery, credit, sales representation and other value-added services, but unlike broadliners, specialty distributors do not carry a full-line of products. Rather, they typically carry a broader and deeper line within their specialization categories.
 - Broadline distributors carry a full-line of products including dry grocery, frozen, supplies, etc. Many broadliners also carry perishable items such as meat, dairy and produce. The typical broadline distributor carries 8,000 to 12,000 stock-keeping units and provides delivery, credit, sales representation and other value-added services to its foodservice operator customers.

Relationships. This is another key success factor. As a supplier, you need to develop relationships with many distributors, because you may end up working with a different distributor when a retailer makes a change.



Warehouses can receive multiple shipments simultaneously through their loading docks.

Distribution centres. Distribution centres, often called warehouses, are a key player in grocery distribution, offering a central location in which volumes of products can be stored for re-sale.

A typical retail distribution network operates with centers set up throughout a commercial market, with each center serving a number of stores. Large distribution centers for companies such as Canada Safeway serve about 50 corporate stores and 100 independent stores. Suppliers ship truckloads of products to the distribution center, which stores the product until needed by the retail location and ships the proper quantity.

Because a large retailer might sell tens of thousands of products from thousands of vendors, it would be inefficient to ship each product directly from each vendor to each store. Many retailers own and run their own distribution networks, while smaller retailers may outsource this function to dedicated logistics firms that coordinate the distribution of products for a number of companies.

Documents necessary for distribution. Several documents will be necessary for the distributor and warehouse.⁷

- **Bill of lading.** A bill of lading (BL – sometimes referred to as BOL or B/L) is a document issued by a carrier to a shipper. It acknowledges that non-specified goods have been received on board as cargo for conveyance to a named place for subsequent delivery to a consignee, who is usually identified. See the attachments for an example and template.

- **Packing slips.** Generated by you (the seller), these must be included with the shipment for product tracking and shipment verification documentation. See the Attachments for an example. Essentials are listed below:
 - Place slip on outside of box, not on the inside (for ease of locating).
 - Do not include the invoice with the packing slip.
 - Do not include product cost.
 - You must note shipper and destination information.
 - You must note the wholesaler purchase order (PO) number, item count and total.
- **Purchase order.** This is a buyer-generated document that authorizes a purchase transaction. When accepted by the seller, it becomes a contract binding on both parties. A purchase order identifies a specific seller and sets forth the descriptions, quantities, prices, discounts, payment terms, dates of performance or shipment and other associated terms and conditions. See the Attachments for an example.
- **Sales invoice.** Generated by you (the seller), the sales invoice should be sent directly to the Accounts Receivable department of the distributor or warehouse, not with the shipment. See the Attachments for an example invoice.

Inbound logistics. In order for distributors to get your product out to stores, your product must first get to the distributor's warehouse (inbound logistics). There are two ways to do this and considerations for each:

1. Drop it off: You drop off the product at the distributor's warehouse. Consider, however, the cost of your gas and time for this option. The distributor will likely be able to transport your product for pennies on the dollar, compared to what it will cost you.
2. Distributor pick-up: Consider whether or not you can pay a pick-up allowance for the distributor to pick up your product from your facility.

NOTES:

- Usually, it is not preferred that products are mailed to a distribution center. This is an inefficient way to transport your products and will likely cost the distributor more money in time and labor to

handle your products. Talk to your distributor about your options and associated costs.

- Separate all distribution costs from product costs on your invoices. Distribution centers and stores track this information separately.

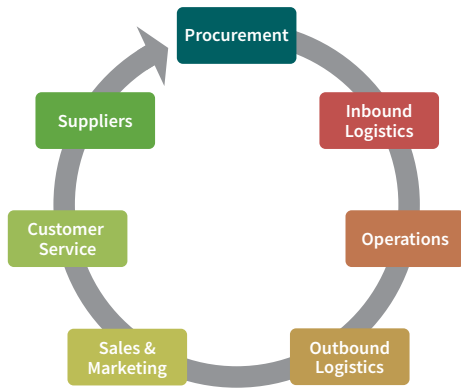

Distribution is just the beginning. This is another key success factor. Now that you've gotten into distribution, you can celebrate for a minute, but your work has only just begun. Your distributor will carry your product from their warehouse to the grocery store. It's up to you to convince the grocery store to order the product from the distributor or warehouse. If stores do not order your product, the distributor and warehouse will not re-order from you.

Because the distributor will be representing you in the market, be aware of and be prepared to offer the promotion tools expected by distributors, such as sell sheets. Methods for promoting your product to grocers, including using brokers, are provided in the *Marketing* section of this manual.



PRICING

Pricing is one of the biggest complaints from retailers in dealing with new small growers and food manufacturers. Many new small growers and food manufacturers do not understand pricing and how it affects their profit and the retail price.⁴ A correct price ensures that you'll have enough profit to promote your product and fund your growth. The correct price means that you may meet your expenses and may be paid a decent return for your efforts.

In contrast, if the price of your product is not correct, soon little else in your business will work. Simply put, if your price is too low, you won't have the profit you will need to fund your business and promote your product. Eventually, you'll be driven out of business.⁹ But how do you figure out what the right price is?

One way to determine your wholesale price is to work backward from a target retail price that is determined based on a combination of strategic positioning and what you think the market will bear for your product. One industry expert indicated that it's common for retail price to be an average of four times your cost of goods sold. Two worksheets are provided for comparing pricing alternatives.

1. **Microsoft Excel interactive workbook.** This workbook (*pricingworkbook.xls*) requires only that you enter a few numbers, and it will calculate the rest for you. You can download this form from the attachments site and open it with Microsoft Excel.³

2. **Pricing worksheet.** This is a worksheet that provides a guide to the pricing formulas. Download from the attachments, print and fill out.

The following details the information you'll need to compute prices.

- **Suggested retail price.** To start, consider: is your suggested retail price (SRP) comparable to other products in the category? If it's more expensive, do you offer unique ingredients or other attributes to make the product a fair value in the consumer's eyes? Does your suggested retail price allow for the industry standard 33 to 50 per cent for the grocer, 20 to 30 per cent for the distributor and maybe five to 15 per cent for the broker, while still providing you with a wholesale price that is enough to make a profit (including marketing expenses and paying yourself)? If not, you will need to re-evaluate your price and your product's fit for grocery stores.
- **Margins.** The net profit (after all expenses) margins for major food retailers are usually in the two to 3.5 per cent range. The gross margins, however, are often in the 25 to 35 per cent range, depending on the category of food product. For example, the margin on a high turn product, such as canned beans, is approximately 30 per cent, while the margin on slow turn spiced mustard may be 40 per cent. As the workbook suggests, talk to a few grocery stores and find out their expected margins. Generally, it is safe to assume that the retailer will require a 30 to 40 per cent margin on food products. The more competitive the product category, the lower the margin. Specialty, perishable and lower volume items have higher margins. Many large retailers have private label products. In this case, no matter how low your price is to the retailer, it almost never will be as low as the private label price.⁵

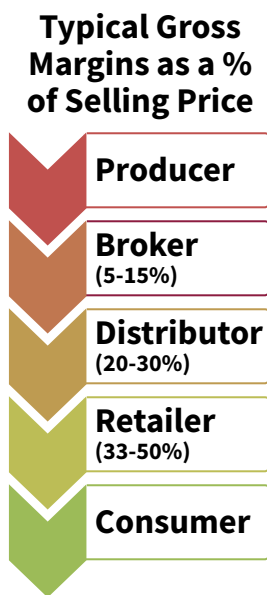

- **Allowances.** View the *Glossary* for explanations of the allowances that can be offered. These allowances should be budgeted as part of your current costing, even if you don't expect to be paying these allowances in the immediate future. This way, should you decide at some point to sell to a corporate retail chain, you will already have budgeted for paying these allowances.
- **Cost of goods sold.** Review the attachment *Costing Programs and Pricing Strategies* to help determine your cost of goods sold (COGS). Your COGS should only include those expenses directly associated with your product, so this includes the food in the package, the unit packaging and label, the case packaging and label, and any direct labour associated with making and packaging the product. These are the only costs your peers/competitors are including as part of their COGS. You should do the same so you are comparing apples to apples. Any fixed costs should not be included as part of your COGS.

Congratulate yourself! Once you've established a reasonably correct cost of goods sold, you have completed one of the most tedious, but necessary jobs involved in determining profits. When you have good data on how profitable your business is, you will be able to adjust your product pricing so your business will run better.⁹

- **Selling, marketing and administrative costs.** Now your focus can shift to the other costs involved in running of your business. These separate costs are lumped together because they use many of the same resources, such as telephone, personnel and office space. Determining this cost also involves lots of number crunching, but the process is less overwhelming than determining the cost of goods sold. All of the entries in this checklist should be self-explanatory to anyone who's been in business for even a short while.

Remember, if you manufacture several items, you must establish costs of selling, marketing, and administration for each product separately. Once you have figured this cost, you have only to calculate costs involved with raising money for your business to summarize your costs of doing business.

- **Figuring how profitable your product is.** Once you've determined the cost of producing, marketing, selling, administering and financially supporting a product, you are closer to knowing how profitable it is and whether it is correctly priced.
- **Determining realistic profit goals.** Now that you've figured your gross profit margin, what does it tell you about how well your product is doing? General guidelines for specialty foods indicate that their ideal wholesale gross margin should be between 40 per cent and 60 per cent. These figures are based on benchmarks or standards in the specialty food industry. Your wholesale gross margin should be no less than 40 per cent. If it is, you won't have enough money to support your product.

You may be surprised that the ideal gross margin has an upper limit of 60 per cent. You may be thinking, huh, why should be a ceiling on the profitability of my product? I thought I was in this for the profits. Well, if your product has a gross margin that is above 60 per cent, competitors will be tempted to imitate your product. For the longevity of your business, it may be better to take less profit or to be sure you're investing the additional profit in activities that will protect your business long-term.

Pricing traps to avoid.⁹ The following should be avoided:

- **You cannot set prices based on anticipated cost of goods savings.** For instance, if you make cookies, you may think to yourself, I can sell my cookies for less than they actually cost because once they catch on and become a hot item, I'll be able to buy ingredients in greater volume. When I can buy 40,000 pounds of flour at once, I'll save so much money that it will make up for everything I lost while the business was growing. Once my business gets really big I'll make more money and be able to bring my price into line with my costs. Until then, I'll skimp on other things. If you follow this practice, you are setting your product up to fail. Don't accept the illogical idea that, someday when I'm bigger, I'll be able to make money at my current price levels.



Remember that to realize the price savings on 40,000 pounds of flour, you need a railroad siding, a flour silo, flour infestation controls and a high-speed production line. The money for all of those things must come out of your current profits or further investment. You may be able to be more competitive because of production savings, but you have to get the price right in the first place or your business won't survive and grow.

- **You must include in your budget and pricing all expenses required or demanded by the consumer and the trade.** By this we mean that all the costs required to get your product to the consumer must be built into your budget and pricing plan. Such costs might include sales commissions, in-store demonstrations, advertising, trade shows, promotions, distributor discounts, freight and customer service. If you don't get your profit margins up to the right level early in the game, you may not have the luxury of surviving a few lean years until your business takes off. Your success hinges on choosing the correct price for your product.
- **You cannot spend money you haven't built into your price.** This includes a decent wage for your workers and yourself. Often people who start specialty food businesses neglect to pay themselves. This is equivalent to contracting for indentured servitude. And for what? So your price will be lower than that of your competitor? Are you willing to risk your family's future because of the fear of a higher price? Newcomers to the specialty food trade tend to give away their product, their

time and their creativity and end up with nothing at all because they are afraid to raise their prices. When the price of your product is correct, you are telling all market segments, I need to make money on my product, even if I choose to fully invest that money into the growth of my company. This is a perfectly laudable statement and shows that you understand the nature of business.

- **You can afford any expenditure that is included in your price.** Do you believe in your product? Do you believe in your company? If so, then you can build nearly any reasonable cost of business into the price of your product. Must you pay slotting fees? They should go into the price of your product. What about the dozens of complimentary golf balls for buyers? They should go into the price of your product. If the buyer at a huge conglomerate market will take your product only if you sweeten the deal with a special allowance, then build the allowance into the cost of your product and get the business if you can handle the volume. Do you want to invest heavily in television advertising and do lots of print ads with coupons? Well, that's why cereal prices are so high. Who do you think pays for the coupons? The consumer does. It's in the price.
- **You must reset prices whenever a material change in costs or expenses is experienced or anticipated.** It is important for you to keep your prices current with your expenses. If you neglect routine monitoring of your costs and fail to raise your prices when necessary, inflation will bleed away your profits. You must forecast changes in costs of materials and adjust your prices as necessary. Are market analysts predicting a rise in the price of glass? Well, raise your price in anticipation of this change. You can always reduce it if the change does not materialize, or use the extra margin to promote your product.

Pricing your product is one of the most important decisions you will have to make. Your price should give consumers what they want but it also must meet your business needs. Remember, consumers will always want it cheaper but that doesn't mean you should undercharge. While the process can be nerve-racking, it may make things easier if you realize that you're not the one who has forced the food industry to rely on costly marketing strategies

to spark sales. You're not the one who has ruled that food must be sold in supermarkets or specialty food emporiums. Rather, by voting with their dollars, consumers have selected the kinds of stores that they prefer. In so doing, they have indirectly voted for the profit margins that are related to each kind of store. Similarly, consumers have selected the kinds of packaging they prefer, along with their related costs. Consumers have expressed preferences for the quality and size of product that they want, as well as all of the various promotional techniques that are involved. Each consumer preference has a price tag and, in the end, consumers must pay for their choices.



BUSINESS PRACTICES

This section begins with an assessment: are you in business, or are you trying to make money off your hobby? This is not to be confused with making money doing something you love. Rather, it's assessing whether or not you plan to run your business in a business-like manner.

As you were asked in the beginning of this manual: is this your full-time business, or are you making product on the side while still keeping a day job? For the sake of the reputation of local products among store owners, we suggest that you should pursue selling your product to more than a handful of grocery stores ONLY if this is your primary source of income. If you are part-time (i.e., NOT at least 8 a.m. to 5 p.m., Monday to Friday), then selling to a handful of grocery stores

is possible, but pursuing warehouse, distribution and non-local stores isn't likely to be successful.

Here are some common food industry business practices that you must consider.

Business hours. Most brokers, distributors, warehouses and grocery stores expect that you are available to conduct business on a regular schedule, usually Monday-Friday, 8 a.m. to 5 p.m. This can be done in your pajamas at home, or it can be done on the road with your cell phone and laptop, but to sell to grocery stores, you must be available during regular business hours.

Technical skills. Do you have the computer programs required for doing business and the skills for running them, such as:

- word processing programs (ex: Microsoft Word) for contracts, invoices and sales flyers)
- accounting software (ex: QuickBooks) for accounts receivable and accounts payable)
- email software (ex: Microsoft Outlook) for quick, inexpensive communication with stores
- website development software (ex: Adobe Dreamweaver) for developing and updating your website. Resources for those with limited skills are available, such as smallbusiness.yahoo.com/webhosting

If you don't have these skills, you can either take the time to learn them from local adult education classes,



online tutorials, etc., or you can hire out. Common skills that are hired out are for accounting and website development and management. The time you free up by hiring out for these tasks can be spent on marketing your product.

The most important message here is that whether you pay for experts or train yourself, your business must have access to these skills.

Insurance. In setting up any kind of business, you will need to consider several types of insurance coverage, including:⁸

- general business liability, including product liability insurance (\$1 million to 2 million standard)
- interruption and specific time element coverage
- property and professional loss

Distributors and most grocery stores will require their suppliers to be covered and will specify that the insurance certificate must name them as an additional insured party. See the attachments, *Small Business Insurance* and *Product Liability Insurance Explained*, for more information.

Invoice terms. These are the payment terms, agreed upon by the seller and the buyer, that are listed on the purchase order. Typical grocery industry terms are Net 30, indicating that payment is due to the seller within 30 days of the origination of the purchase order. This means that you must be able to float the inventory cost of sending out product and waiting 30 days to receive payment. If it is important to you to receive payment faster, you can offer a cash discount for early payment, such as a two per cent discount if the buyer pays the seller within 10 days of the origination of the purchase order (or after receipt of product).

Typically, independent grocers pay Net 30, while some larger chain stores will pay anywhere from Net 45 to Net 90, depending upon their size and buying power. You of course would like your payment as quickly as possible, so you can try asking for Net 15 but if the customer pushes back on this, you can then ask them what they would prefer and adjust your terms for that customer accordingly.



MARKETING

You will need to have a marketing plan ready when you approach distributors and stores, indicating that you have thought about and have the support in place for the entire delivery system. The following are the considerations for your plan.

Brokers. Your first consideration is whether or not to hire a broker as part of your marketing plan. Distributors and grocery stores look favorably on the use of brokers because of the convenience of working with an established relationship that provides access to multiple product lines in one visit. However, there is a cost associated with hiring a broker, so you should weigh the benefits carefully against your bottom line.

The food industry defines a broker as an independent organization functioning as a sales representative for multiple growers and food manufacturers, usually rewarded by a commission against sales. Brokers are sometimes also called manufacturer's representatives.

Some of the advantages of appointing a broker are:¹

- knowledge of the local market conditions
- existing professional relationships with the grocery stores
- overall experience in representing multiple lines of products that may include yours
- end user calls
- specialization in food service, retail grocery, bakery and deli and other specialty categories

When you enter into business with a broker you are, in essence, giving the broker a licence to use your product to hunt for business in a specific territory. Entering into a relationship with a broker hitches the future of your company to the broker's efforts. If the broker is diligent, engaging and smart, you will be more successful. If the broker is disorganized or isn't focused on selling your line, your sales volume will sag. So you should engage a broker cautiously.

Further investigation into the pros and cons of a broker is available in the attachment, *The Role of Distributors and Brokers*. More information on how to engage a broker is available in the attachment *Working with a Broker*.

Hiring a broker cannot be your entire marketing plan, however. You must continue on with developing your marketing plan.

Distributors. From the section on distributors, you should have decided whether or not to work with a distributor for selling to grocery stores. Your marketing plan for distributors should be two-fold:

1. how to entice a distributor
2. once in distribution, how to sell the product out of the distribution center to the grocery stores (i.e., supporting your distributor).

- **Enticing a distributor.** View the attachment *Information to Include in a Distributor Presentation*.⁹ Most of the items in this checklist have been addressed in previous sections. Make sure you have all of these items addressed before you begin distributor calls.

- **Supporting your distributor.** For the distributor who takes the risk (and opportunity) of carrying your products, you must provide support to help them move your product out of the warehouse and into the stores.

- Store visits: Whether you use your broker or do this in person, plan on making sales calls to the stores in your distributor's route.

- Sell sheets: Prepare sell sheets, also called new item introduction sheets, that your broker and distributor can provide to stores in their route, encouraging them to try new products in the convenient distribution system. Some distributors may have a free system for delivering sell sheets

to stores. Find out from your distributor if there is a free or inexpensive and easy method of getting sell sheets to stores. See the attachment *New Item Intro Sheets* for examples.⁷

Important information conveyed to grocery buyers through this sheet includes:

1. picture of product
2. your contact information
3. distributor's item number
4. item description (ex: organic cheddar cheese)
5. case and unit cost
6. case pack information (ex: 24/7oz.)
7. suggested retail price (SRP) with margins
8. shelf life
9. handling instructions
10. merchandising suggestions (ex: in the deli section)
11. product attributes (ex: flavor, size)
12. product uses (ex: great for marinade)
13. reason they should buy it (ex: bun variety sales are increasing)

Grocery buyers. Your marketing plan for grocery buyers should be two-fold:

1. how to get stores to carry your products
 2. once on the shelves, how to get consumers to buy your product (consumer marketing)
- **Marketing to stores.** Whether you are planning on direct-to-store delivery (DSD) or working with a distributor, you must have a plan for how to get stores to carry your product. As mentioned before, you should plan on store visits, providing sell sheets and offering allowances.
 - **Consumer marketing.** Consumer marketing is a potential black hole for small manufacturer's marketing dollars. For the purposes of this section, we will limit the consumer marketing ideas to those that specifically support grocery stores. See the section on *Trade Promotions* for guidance.

Trade promotions. Simply defined, a trade promotion is an activity that encourages the distributors, grocery stores and consumers to purchase your product. If you've bought something on special or clipped a coupon, you've participated in a trade promotion.

In today's highly competitive, product-saturated, specialty food marketplace, a product must sell well immediately to stay on the shelves. And it must continue to sell well to stay there. Because effective promotions encourage both the trade and consumers to buy your product, they offer a competitive edge. Carefully designed promotions can dramatically increase your sales and profits.⁹

- **Funding.** Promotions will cost you money, but if you have priced your product correctly you'll have promotional costs already built into your price and your budget. Having planned in advance for this expense item lets you promote your product when you are ready. Don't think of promotions as an expense to avoid, but as a tool to increase sales.
- **You control promotions.** The main goal is to increase your sales and profits. When you develop a promotion that works in one marketplace, you'll want to take it to another geographic area, repeating it again and again. By tinkering with your promotions and monitoring their effects on your sales, you'll soon have a number of proven promotions that are custom-tailored for your product in various situations.
- **Promotions have specific objectives.** Promotions are an investment in your product. Before, during and after the promotion, you will monitor sales so that you may clearly evaluate the effectiveness of the promotion. As a guide for future programs, you should be able to identify those promotions that worked for you and those promotions that didn't.



- **One size does not fit all.** Promotions that work for another company or product may not work for you. Guided by careful analysis, experimentation will allow you to find your winning promotions.
- **Types of promotions.** There are three broad categories of promotions (see the attachment *Trade Promotions Examples* for detailed information on each):
 1. introductory promotions that stimulate interest in a new product
 2. repeat (scheduled) promotions that stimulate the market on a regular basis
 3. specific activity promotions that are tied to a specific action to be performed by the distributor, store, or consumer
 - *Introductory promotions.* These are designed to jump-start sales of a new product and establish a relationship with a new distributor, store or consumer. With promotions, you give an allowance, such as a sum of money (or its equivalent in goods) to a distributor or store to encourage some action associated with sales of a product. There are many different kinds of introductory allowances, including slotting (a sum of money or goods given in exchange for initially stocking a product), trial-size offerings, free goods, set-up and buy-out.
 - *Scheduled or repeat promotions.* These are designed to influence the purchasing and sales pattern of your current customers by supporting a specific event. In each of these repeat promotions, payment is related to either the amount that is purchased or the amount sold by the distributor or store.
 - *Specific activity promotions.* These include allowance varieties such as catalogs, show promotions, placements, demonstrations, samplings, point-of-sales, fixed payment advertising and fixed payment co-ops. For instance, placement allowances are promotional activities for which the supplier pays a specific amount to obtain a desired shelf location or position.

Common allowances or promotions not covered in the *Trade Promotions Examples* attachment are as follows:

- **Exclusivity.** Retailers will likely request exclusivity for a channel, region or a specific period of time. You may give exclusivity to a retailer in an area in trade for a commitment to a specific volume of sales over a limited period of time.
- **Regular co-op/co-operative advertising allowance.** This is usually a percentage of the net invoice amount, but sometimes it's a case amount. It's offered to assist with the retail advertising and promotion of a product. It's normally paid on a quarterly basis (ex: three per cent).
- **Volume rebate.** This is used to encourage additional sales over a given period, normally one year. It's based on an estimated level of movement during the year. The rebate is paid quarterly as a percentage of the invoice price, based on actual sales. At the end of the year, an adjustment is made on the final payment to reflect the actual purchases over the year (ex: zero per cent paid for sales up to \$10,000; 0.5 per cent paid for sales from \$10,000 to \$30,000; and one per cent paid for sales from \$30,000 to \$60,000).



- **Advertising allowance.** This is an allowance offered to assist in retail advertising of a product in a specified form (ex: newspaper ads, radio or TV spots or flyers, generally within a store group).
- **Freight allowance.** You can peg these to volume orders. For example, you might offer a five per cent freight allowance for any order over 50 cases of assorted product. This means that the buyer may deduct five per cent of the freight on board (FOB) invoice amount from the payment. The idea is to encourage larger purchases by offering the benefit of economy to the buyer.
- **In store demonstrations and tastings.**⁴ Consumers tend to buy products they have sampled, usually at sample tastings conducted at the point of purchase. These can involve a demonstrator, your product and the means of sampling (crackers with cheese, for example). The demonstration is conducted during high traffic periods, over the course of three to six hours. Consumers have the opportunity to taste your product, to comment on it, to hear a pitch from the demonstrator, and to purchase. Often, demonstrations are accompanied by a special product price used to entice the consumer into making an immediate purchase.

A typical demonstration might be conducted from 10 a.m. to 3 p.m. on a Saturday. The idea is to get as much public attention as you can, so peak shopping hours are best for demonstrations. Talk to the store about their sampling policy. Some stores offer their own staff for samplings, given that you provide free samples (see *Sampling Allowance in Trade Promotions Examples* attachment). Conversely, demonstrator costs will be in the neighborhood of \$15 to \$25 per hour, with a \$100 to \$125 minimum fee per day. An alternative to in-store sampling is to provide the consumer with a coupon for free product to try at home.

- **POP materials.** As the name implies, point-of-purchase (POP) materials attract the consumer's attention and educate them on the benefits and uses of the product at the point of purchase. Many retailers find POP materials useful in creating attractive displays and interest in their stores. See the attachment, *Point of Purchase Materials*, for more information.⁴

- **Product satisfaction guarantee.** Part of the challenge of providing good customer service is identifying ways to help customers understand that the products or services they receive are guaranteed by the company providing them. Customer service guarantees can be part of a customer service strategy and can be simply stated or very complex. Either way, they communicate the company's intent to stand behind the product or service they provide.



Customer service guarantees are communicated in different ways. Sometimes, there is a sign stating the written guarantee in the waiting room of a business or it may be written in an informational pamphlet or incorporated into information shared on a company's website. No matter the format, it is important to put a guarantee in writing so customers have a comfort level in using products or services.

Probably the best way to launch a new product in a store is to ask the retailer what are the most successful methods in their particular store.

Marketing Strategies

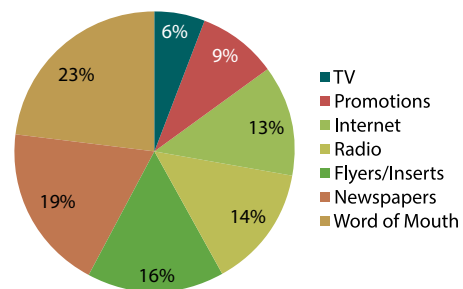

Helpful information. Below are the results of two surveys of grocers, provided for your consideration when developing your presentation.⁵

- **Criteria grocers use to decide which food products will be placed in the store.** Listed in order of preference:
 1. shelf space
 2. customer recommendations and requests
 3. sales history
 4. promotion help
 5. new product
 6. ability to restock
 7. product category
 8. option to consign
 9. price
 10. supplier recommendation
 11. label in English and French
- **If grocers had to choose only one criterion.** Listed in order of preference:
 1. evidence that a product meets all government standards
 2. amount of gross profit
 3. product must have a bar code
 4. evidence of the product's previous sales
 5. promotional help



6. supplier must guarantee a specific delivery schedule
7. supplier must be responsible for restocking
8. must have liability insurance
9. evidence of delivery volume capabilities or a minimum amount of inventory
10. supplier must agree to furnish a display

Your success or failure getting into grocery stores largely depends upon your preparation. If you've gone through all the steps so far in this manual, you should be ready for making your presentation to distributors and stores.

4 MAKING THE PRESENTATION

You are now fully prepared for starting the process of selling to grocery stores. This section will give you step-by-step instructions for setting up, making and following-up on the presentation.

Chicken or the egg? A question that will likely plague you as a first-time entrant into the grocery store industry is which comes first: distribution or grocery store sales? Getting placed into most grocery stores is easier when you're already in their distribution system, but most distributors would rather you have established sales before they take you on. So which comes first? Your best bet is to start out by approaching and getting into a few stores first, establishing sales patterns, and then approaching distributors. So, to start, we'll prepare you for the presentations to your first few stores.

Brokers. If you employ a broker, this process will be much simpler for you, as the broker should already have in place the relationships, meetings and follow-up necessary. However, in the beginning, it is appropriate for you to ride along with the broker to see how this process is carried out, so you can duplicate it in areas not covered by your broker(s).

The set-up. To set-up the meeting with the grocery store buyers, begin as follows:

1. *Find the contact information for the appropriate buyer.* Purchasing is done by buyers or category managers, depending on the size of the distributor or store. Larger stores have category managers who purchase and maintain products in their category or categories for many stores.

If you are planning to call on an independently-owned store with only one location, they will not have a dedicated buyer or category manager. The buyer or decision maker in that case may be the store owner or manager. If your item is something that is specifically targeted to a perimeter department such as meat, deli, produce or bakery, the decision maker may be the department manager.

For approaching an independent grocery store, the best way to determine who you need to talk

to is to visit the store and ask. Start with the department manager of a perimeter department if your item is targeted there. Otherwise, ask the assistant manager. Once you determine who you need to present to, you may be able to present to that person immediately or you can ask to make an appointment to come back another time.

Buyers and category managers deal with many people and have a good understanding of what their customers want. They decide which products will be placed in their warehouses or on store shelves and work with brokers. Some chains have centralized purchasing for all stores.

It is likely that Internet research will not turn up the appropriate contact for independent grocery stores, unlike larger chains. So your best bet is to call the store directly. Ask the person answering the phone to give you the name of the appropriate buyer or category manager and the preferred time and method for reaching them. A general suggestion is to call early in the morning, 6:30 or 7 a.m., as many buyers are at their desks very early, answering emails and getting ready for the day. Also, call late in the day as many buyers stay late to return calls and email messages.

Be careful! This call may end up being routed to the buyer, so you must be prepared to give your 30-second product introduction just in case. Also, understand that this contact will not likely result in placement in the store. Rather, from this conversation you will get the buyer's preferred or mandated way of reviewing prospective products.





By identifying yourself as a grower or manufacturer interested in first-time sales to their store, it is likely you will be provided their standard New Item Presentation packet to fill out in advance of an in-person meeting. Just in case, here are the items you must have prepared – sometimes referred to as your elevator speech:²

- Who are you and what is the name of your company?
- Who referred you (ex: the name of a store, buyer or manufacturer)?
- Why you are calling?
- What is the product?
- What makes the product different?
- What are the key features and competitive advantage?
- Who you are selling the product to and where it is being sold?
- What are your target retail and wholesale price points?
- What is your product position – ex: health/wellness, decadence, convenience?

2. *Make the first contact.* If you weren't routed immediately to the buyer, your contact information research should have yielded the preferred method for contacting the buyers, so start there. In all likelihood, because small independent grocery stores also keep small staff (ex: the owner might be the buyer, manager and accountant), they will prefer you fill out their required documentation (see attachment *New Product Introduction Forms*

Samples) and send a few samples for them to try. If they're interested, they'll contact you to set up a meeting in-person. It doesn't hurt, however, to follow-up a week after you sent the product samples, asking them to give you an indication of their interest.

3. *Ready your presentation.* You should be ready to develop your presentation. Go over the notes you took throughout the manual, specifically those that covered how your product is better than the competition and how your business is poised for grocery store sales. While being prepared to provide information on all of the scenarios presented in this manual, common elements developed for a presentation are as follows², and you can refer back throughout this manual for explanations and guidance:

- *Company profile.* This is a one-paragraph explanation of the background of the company (location, ownership, length of time in business, employees) and one paragraph on how you're qualified to run this company (passion counts!). Remember to bring business cards to your presentation.
- *Product.* Bring at least two samples, one for them to open and taste and the other to hold up as a pristine and undisturbed example of the packaging you offer.
- *Production.* Bring pictures of the production plant and give an explanation of plant's ability to ramp-up production, quality control standards (HACCP, GAP/GHP, etc.).
- *Pricing.* Bring price lists. Make sure you've done your research ahead of time and are able to quote both wholesale and suggested retail prices. Preface your pricing discussion on the fact that you've done store audits and understand what pricing it will take to be competitive.
- *Retail sales.* Provide general information on stock turn, retail margins, sales growth over time, promotional programs, etc. to help the risk-adverse grocer to feel better about taking a risk with your product
- *Market information.* Any market research on the category that can justify the existence and marketability of your product would be useful.

- *Distribution.* Is your product being sold to majors (large, national stores) or independents?
 - *Exclusivity.* Are you offering exclusivity or an area or for a channel in an area?
 - *Certification.* Is your product certified organic, natural, kosher or local?
 - *Competitive price points.* Talk about your margins, usually higher than majors due to slower turns.
 - *Minimum purchase requirements.* Talk about your minimum requirements, either for units or case lots.
 - *Service.* Weekly? Monthly?
 - *Point of sale material.* How you plan to support the purchase of your product in-store?
 - *Commitment.* Be prepared to ask for some level of commitment from the buyer. Bring order forms and don't be afraid to ask for the order!
4. *Follow-up.* Follow-up is a key component of the meeting and is often overlooked. Always follow-up in 24 hours on any required information from the meeting. It is also a good practice to thank the buyer for meeting and confirm the next meeting date, if necessary (or thank them for the order).

Now don't blow it! Remember, more than 2,000 new food products are introduced in Canada each year (over 20,000 in the U.S.), and 90 per cent of these products will fail on the shelf. From industry surveys, it has been indicated that price, image and taste were the primary reasons that new products did not achieve a level of sales high enough for them to remain on the shelf after one year.

Lessons to keep in mind. Additional reasons why retailers stopped ordering products were:⁹

1. Product quality was misrepresented.
2. Some aspect of support was not received.
3. Product was also sold to mass merchandisers and other price-based retailers.
4. There was a failure to follow agreements and conditions of purchase.

5. There were high incidents of breakage.
6. The product was unstable.
7. The company didn't stand behind their product.
8. There were unresolved credits.
9. There were high freight charges.
10. There were unreasonable minimum purchase requirements.
11. The suppliers were unresponsive.
12. There was inconsistent pricing (ex: a supplier with a number of price lists).
13. There was a high out-of-stock rate for an extended period of time, making availability of product a question.
14. The product has so many brand extensions, the store never has a complete line. Pieces and parts of lines like these are generally found at different prices in a number of stores in a given market.
15. There was a heavy commitment to the product made on the promise of exclusivity, only to find the agreement broken.
16. Lack of sales support in the form of allowances for quantity pricing, demonstrations, advertising and sampling.
17. There is a packaging problem that makes the product hard to use.
18. The product has too many steps or is too complicated to use.
19. There was a poor perceived value.
20. The labeling promises more than it delivers.

That's all! You made it! Good luck with the process! If you need additional help, feel free to contact:

www.manitoba.ca/agriculture
 mbagrifood@gov.mb.ca
 204-239-3362
 810 Phillips St, Box 1240
 Portage La Prairie, MB R1N 3J9

5 GLOSSARY

- *Accounting cycle:* An accounting cycle is a period of time for which a financial performance analysis is conducted. It is usually a month, quarter or year.
- *Accrual:* This is the amount of funds earned through purchases over a stated period. It is usually earned on the basis of so much per dollar or per item purchased.
- *Accrual period:* This is the period during which purchases accrue allowances.
- *Ad scrip:* This is a certificate entitling a retailer to a specified amount of co-op funding. It is often used as a means to provide allowances to indirect customers. Sometimes called co-op in a box.
- *Advertising deadline:* This is the last date by which advertising may take place if it is to qualify for reimbursement.
- *Affidavit of performance:* This is a sworn statement that provides information about certain advertising. Typically, it refers to a statement from a medium, such as a radio, cable, or television station or an outdoor supplier.
- *Approved source:* An approved source is used to indicate suppliers that are authorized by a food service management company or a distribution company to sell products to that company.
- *Audit:* An audit is a process by which a claim is analyzed and a determination made as to whether a claim falls within program guidelines and, if so, how much should be paid.
- *Automatic inventory replenishment:* This is an arrangement by which a retailer authorizes a manufacturer to monitor the retailer's inventory of the manufacturer's products and automatically ship additional products when inventory reaches certain levels.
- *Back-haul:* A back-haul is moving freight from the destination point back to point of origin. If a trucker takes a load from point A to point B, the back haul is a load going from point B back to point A.
- *Barter:* Barter is the trading of merchandise instead of paying cash for advertising.



- *Beginning inventory:* This is the wholesale dollar amount of inventory on hand at the beginning of an Accounting Cycle.
- *Bill of lading:* A bill of lading is the shipping document that transfers the title or ownership of the freight from one party to another.
- *Carryover period:* This is the period after the end of a co-op program, during which a retailer can spend funds left over from the program.
- *Category killers:* This is a class of exceptionally large retail stores that are devoted to one category of merchandise, such as Home Depot and Best Buy. They are also called superstores.
- *Claim:* This is the invoice from a retailer or other intermediary for reimbursement of the cost of advertising or promotion of a supplier's product or service.
- *Cooperative advertising:* This is any arrangement by which a product or service is brought to public notice over the names of both the supplier and any intermediary who comes between that supplier and the ultimate purchaser. The intermediary may be a retailer who buys a product for resale, a distributor who sells to retailers or other form of intermediary. This arrangement results in consumer advertising as well as other forms of promotion. The cost of the promotion may be shared by the supplier and the intermediary or the supplier may pay all costs. The process commonly involves reimbursing retailers for advertising they create and place.

- *Common carrier:* A common carrier is a freight transportation company or sole driver acting as his own company who serves the general public for transport jobs. He may offer a regular route or take unscheduled trips on irregular routes, depending on where he is authorized to serve.
- *Cost of goods sold (COGS):* This is the actual cost of all items sold in a department (or entire store) during an accounting cycle. COGS includes the cost of an item plus freight, minus any purchase discounts. COGS is computed by: Beg. Inventory + Purchases – End. Inventory = COGS. Stated simply: We already had this much inventory, we added this much to it (through purchasing), we still have this much inventory, the difference must represent the cost of what we actually sold.

Example: Beg. Inv. = \$25,000, Purchases = \$75,000, Ending Inventory = \$23,000

COGS = \$25,000 + \$75,000 – \$23,000 = \$77,000.

- *Contribution to margin:* Contribution to margin represents one department's contribution to the total store's gross margin percent and is expressed as the number of margin points contributed by a department. Contribution to margin is computed by:

Actual Department Gross Margin Percentage x Department Percentage of Total Store Sales.

Contribution to margin data can be used to help create a pricing strategy that achieves gross margin targets, while remaining price competitive with other stores. Example: The total store needs to deliver a gross margin of 34 per cent: The grocery department produces a gross margin of 34.53 per cent and grocery comprises 62.13 per cent of total store sales. 34.53 per cent x 62.13 per cent = 21.45. Grocery contributes 21.45 points of the total store 34 per cent target margin.

A price analysis of our competitors shows that we cannot afford to increase the prices in the grocery department. This means that the other departments must produce a combined margin contribution of 12.55 points or an average gross profit margin of 33.11 per cent (37.87 per cent of total store sales X 33.11 per cent average gross profit margin) for the store to achieve the total store target margin of 34 per cent. This type of analysis may be performed on every item within a department in

the same manner. This can help you to be price competitive within your department while still achieving gross margin targets.

- *Credit memo:* An alternative to cash as reimbursement to customers for cooperative advertising. The supplier issues a credit memo that authorizes the retailer to deduct that amount from the next payment to the supplier.
- *Days in turns:* This is the number of days it takes to sell the entire inventory of a given department or the total store. Days in turns is computed by: Days in the Accounting Cycle divided by Inventory Turnover ratio. Days in turns is a ratio that measures the productivity of inventory. You may hear a grocer use the term productivity when referring to sales as well as to inventory turns.

Example: Inventory Turnover = 12. Annual Accounting Cycle of 365 days.

$365 / 12 = 30.42$ (rounded to 30 days in turns.)

Actual data is compared to industry targets and store historical performance for analysis.

- *Deadhead:* A deadhead is a truck driving without a trailer.
- *Deal or deal period:* This is a time frame during which a manufacturer offers products to its customers at unusually low prices and/or with other inducements, such as increased co-op accruals or volume rebates. It is most common in the packaged goods industry. Some deals may induce a customer to buy more products than can be sold during the deal period, leading to diverting.
- *Deduction:* This is a retailer's subtraction of co-op charges from the supplier's invoice.
- *Direct customers:* This refers to customers who buy directly from the manufacturer without going through a wholesaler.
- *Discount recovery:* For products you put on sale, discount recovery refers to the increase in sales needed to produce the usual gross margin dollars the item generates.
- *Diverting:* The practice of buying a product on deal in one area and reselling it in another area where it is not on deal is called diverting. This is often done by retailers who resell to other retailers or to other divisions of their own company.

- *Efficient consumer response (ECR)*: ECR is a catch-all term covering a variety of actions undertaken by many food and packaged goods manufacturers, distributors and retailers to improve distribution practices and clean up abuses in the industry. Trade allowance practices, including deductions, are a major component of the process.
- *Electronic data interchange (EDI)*: This refers to a variety of techniques by which firms communicate with each other, generally through computers tied into dedicated networks, using standardized formats.
- *Ending inventory*: The wholesale dollar amount of inventory on hand at the end of an accounting cycle.
- *Failure fees*: These are payments made to retailers when a product is discontinued due to lack of movement.
- *GAP/GHP*: The purpose of the voluntary Good Agricultural/Good Handling Practices (GAP/GHP) audit program is to verify conformance to generally recognize good agricultural and handling practices, as outlined in the Food and Drug Administration (FDA) Guide to Minimize Microbial Food Safety Hazards for Fresh Fruits and Vegetables. The FDA provides audit services to fruit and vegetable suppliers in the U.S. and Canada. Canada GAP is a program developed in Canada to promote good agricultural practices for fruit and vegetable suppliers.
- *Going in gross*: The gross margin percentage used to determine the retail price of an item. Because of shrinkage, going in gross is seldom realized.
- *Gross margin dollars*: This refers to the sales dollars left over after paying for COGS.
Example: If sales = \$100,000, and COGS = \$67,000, then gross margin dollars = \$100,000 – \$67,000 = \$33,000.
- *Gross margin percentage*: This is gross margin dollars expressed as a percentage of actual sales.
Computed by: gross margin dollars divided by sales
Example: \$33,000 divided by \$100,000 = 33 per cent gross margin.
- *Hazard Analysis Critical Control Point (HACCP)*: This is a food production, storage, and distribution

monitoring system for identification and control of associated health hazards. It is aimed at prevention of contamination, instead of end-product evaluation. In place of relying on food inspectors to detect food safety problems, HACCP shifts the responsibility to the food producer to ensure that the product is safely consumable.

- *Inventory productivity*: This is data used to evaluate the financial performance of the asset inventory. Some inventory productivity ratios are: inventory turnover, days in turns and inventory per square or linear foot.
- *Inventory turnover*: A ratio describing the number of times in a year that the entire inventory of a department (or the whole store) sells or “turns over”. Inventory Turnover is computed by: COGS divided by Average Inventory.
Example: Beg. Inv. = \$28,000 End.
Inv. = \$33,000 COGS = \$530,000
First compute average inventory: $28,000 + 33,000 = 61,000$
 $61,000$ divided by $2 = 30,500$, so average inventory = \$30,500
 $530,000$ divided by $30,500 = 17.38$. The inventory turnover rate is 17.38 turns per year.
This ratio is an indicator of inventory productivity. Actual data is compared to industry averages and the store’s historical performance. A high number is considered fast turnover and a low number slow. Fast turns are generally desirable, but in some circumstances, may indicate that you are losing sales through not having enough product on hand. Slow turns may suggest that there is excess inventory in a given department, or that the pricing, product mix and merchandising need modification.
- *Just-In-Time*: This is the concept of cutting inventory costs by ordering supplies only as needed. It was pioneered in manufacturing by the Japanese, and is now increasingly popular among retailers.
- *Key market funds*: These are funds over and above the normal co-op allowances made available by suppliers for use, only in certain markets in which they have a strong interest.

- *Mark-up*: This is the term used to describe the ratio of the gross margin dollars of an item divided by the cost of the item. Many people use the terms margin and mark-up as though they mean the same thing, but they are very different. One of the main differences: mark-up percentage is based on cost, whereas gross profit margin percentage is based on retail. The only time mark-up percentage is used in the grocery industry is at the wholesale level, where a mark-up or upcharge is added to the cost of a case of product as the wholesaler's fee to move that case to the retail stores.
- *Market development funds (MDF)*: This is extra funding given to specific retailers for specific purposes, such as a major seasonal promotion, by the manufacturer's sales or marketing management.
- *Merchandising*: This refers to the display and promotion of products.
- *Multi-vendor programs*: This refers to programs in which two or more manufacturers jointly offer a promotion to their retailers.
- *Off-invoice*: This is the practice of taking an allowance directly off the price of the product, rather than submitting a claim for payment of the allowance.
- *Overbill*: This is a practice among some retail buyers who ask suppliers to bill in excess of the regular price and hold the excess funds at the buyer's disposal to be used for promotional or other purposes. It is sometimes stimulated by management pressure on the buyer to seek money over and above the supplier's regular allowance. In other cases, buyers use this approach when they want to promote an item for which no store funds are available. In some industries, called price loading.
- *Pay for performance*: This refers to programs offering to pay retailers a specified amount for each unit of the manufacturer's product sold during a specified period, usually based on scanner data.
- *Pricing strategy*: This is a formal plan that determines how the store will achieve target gross margin. Often neglected in co-ops, the pricing strategy is a key factor in creating a positive price image for the store. Through the use of variable margins the purchaser strives to maintain competitive pricing while achieving target gross margins.
- *Purchases*: This is the net cost of items plus freight, minus discounts during an accounting cycle.
- *Push money*: This is the practice by which a manufacturer offers cash or other inducements to a retailer's salespeople to encourage them to recommend its products to potential buyers. The most common format is to offer the salesperson a certain amount per unit sold during a specified time period. A common variant is to offer points, which the salesperson can use to buy various merchandise from a manufacturer-supplied catalog. These are also known as spiffs.
- *Reefer*: This is a nickname or trucking term for a refrigerated truck.
- *Radio Frequency Identification (RFID)*: RFID is used to locate a product in transit anywhere in the world. RFID tags can be as small as a grain of rice.
- *Sales contest*: A sales contest is a form of push money in which, instead of offering cash incentives, the manufacturer offers participating retail salespeople the opportunity to win some kind of prize, either through a drawing or by achieving defined levels of sales.
- *Shrinkage*: This refers to lost gross profit margin due to spoilage and breakage, mispricing, misringing, discounting and theft.
- *Soft dollars*: Soft dollars are promotional allowances.
- *Stock-keeping unit (SKU)*: SKUs are used by retailers to track their inventory. Each unique item or SKU is identified by a unique UPC. If a line of product has five flavours and there are two sizes of each flavour, this means the line has a total of ten SKUs.
- *Stock To Level*: This is a predetermined, target on-hand inventory level for each item in a given department. The purchaser conducts a count of inventory on-hand, compares the result to the Stock To level and places an order for the difference. This is a valuable tool for maintaining good inventory turnover. When determining the Stock To level, you want to make sure that there is enough product to create an attractive display, while minimizing back-stock.

**Often vendors will offer quantity purchase discounts on some items that may justify exceeding Stock To levels. Understanding turn and earn ratios will help to determine if it is advantageous to buy these items in quantity.

- *Trade loading*: The practice of inducing retailers or distributors to take on unusually large amounts of merchandise, generally by offering exceptional prices or terms, is known as trade loading. It is often done at the end of a quarter or other finance reporting period in order to reach quotas.
- *Turn and Earn*: A purchaser strives to achieve high Inventory turnover. You also want to earn maximum gross margin dollars. For example, if a vendor is offering a discount on quantity purchases of an item you may want to take advantage of this to earn extra gross margin dollars. However, to do so, requires a greater investment in inventory that will lower inventory

turnover ratios. To reconcile these two elements, the turn and earn ratio was developed. Turn and earn is computed by: $\text{inventory turnover} \times \text{gross margin percentage}$. At the end of an accounting cycle, if inventory has increased but turn and earn remains constant, you may assume that the inventory increase was due to quantity discount purchasing. If the turn and earn ratio goes down, then the inventory increase has been caused by other factors that you will want to investigate.

- *Variable Margins*: Refers to the application of different Gross Margin % to items in the same department. To be priced competitively on high-visibility items (a key element of the Pricing Strategy), you may have to use a lower Gross Margin % on those items. In turn, to meet department target Gross Margin % you will have to price other items above the target to make up for items priced below target.

6 ATTACHMENTS

ATTACHMENTS

The following is a list of the attachments associated with this manual. You can download these attachments from our website: manitoba.ca/food

1. Bill of Lading Sample
2. Bill of Lading Template
3. Case UPCs
4. Costing Programs and Pricing Strategies
5. Information to Include in a Distributor Presentation
6. New Item Introduction Sheets
7. New Product Introduction Form Samples
8. Packing Slip Example
9. Per-kilometre Costs of Operating Automobiles and Trucks
10. Point of Purchase Materials
11. Pricing Workbook (Microsoft Excel Interactive)
12. Pricing Worksheet
13. Product Liability Insurance Explained
14. Purchase Order Sample
15. Sales Invoice Template
16. Small Business Insurance
17. Supply Chain Basics: Technology – How Much, How Soon
18. The Role of Distributors and Brokers
19. Trade Promotions Examples
20. UPC Barcode Basics
21. Western Montana Independent Grocer Survey
22. Working with a Broker



7 REFERENCES

Following are the resources used for developing this manual. The numbers correspond with the citations.

1. *Are Food Brokers Right for You?* Jim Brooks, Robert M. Kerr Food & Agricultural Products Center, Oklahoma Cooperative Extension Service. <http://pods.dasnr.okstate.edu/docushare/dsweb/Get/Document-986/FAPC-130web.pdf>
2. *Canadian Grocery Retail Guide*. Saskatchewan Grocery Retail & Foodservice Value Chain Initiative. 2010. <http://www.saskvaluechain.ca/retailguides.htm>
3. *Fidyk, Jeff, Business Development Specialist – Consumer Trends*. Food and Agri-Product Processing Branch; Manitoba Agriculture; jeff.fidyk@gov.mb.ca. Email interview. 2011.
4. *From Kitchen to Market: Selling Your Gourmet Food Specialty*. 2010. Stephen F. Hall, Kaplan Publishing, eBook Collection (EBSCOhost), EBSCOhost. <http://SpecialtyFoodResource.com>
5. *Grocery Retailers in the Northwest*. Jill A. Beaman, faculty research assistant, and Aaron J. Johnson, food business strategy specialist; both of the Food Innovation Center, Oregon State University, 2006. <http://library.state.or.us/repository/2007/200701021509082/index.pdf>. Used with permission.
6. *How to get Value-Added Products into Local Grocery Stores*. Rob Holland, The University of Tennessee Agricultural Extension Service's Center for Profitable Agriculture & Tennessee Department of Agriculture, 2003. <http://utextension.tennessee.edu/publications/Documents/PB1719.pdf>
7. *Laroque, Kurtis*. Associated Food Stores, Helena, MT. Personal interview. September 15, 2011.
8. *Starting a Specialty Food Business in Utah*. [Salt Lake City]: Utah Department of Agriculture and Food, Division of Marketing & Development, 2009. http://www.ususdbc.org/library/_commercial_kitchen/Specialty%20Food%20Business.pdf
9. *The Basics: The Business of Specialty Foods*. [New York]: National Association for the Specialty Food Trade, 2009. Print. http://eo2.commpartners.com/users/nasft/downloads/Basics_Archived_Webinar_SFF10_Part_4.pdf
10. *The Per-mile Costs of Operating Automobiles and Trucks*. Gary Barnes, Peter Langworthy, Minnesota Department of Transportation. June 2003. <http://www.lrrb.org/pdf/200319.pdf>
11. *Van der Jagt, Paula, Manager; Joel Franjevic, Assistant Manager; Mitch Opsta, Grocery Manager*. Van's Thriftway, Helena, MT. Personal interview. October 12, 2011.
12. *Western Montana Independent Grocer Survey*. Lake County Community Development Corporation's Mission Mountain Food Enterprise Center located in Ronan, Montana. 2010.





MANITOBA AGRICULTURE
mbagrifood@gov.mb.ca
manitoba.ca/agriculture